

Mass

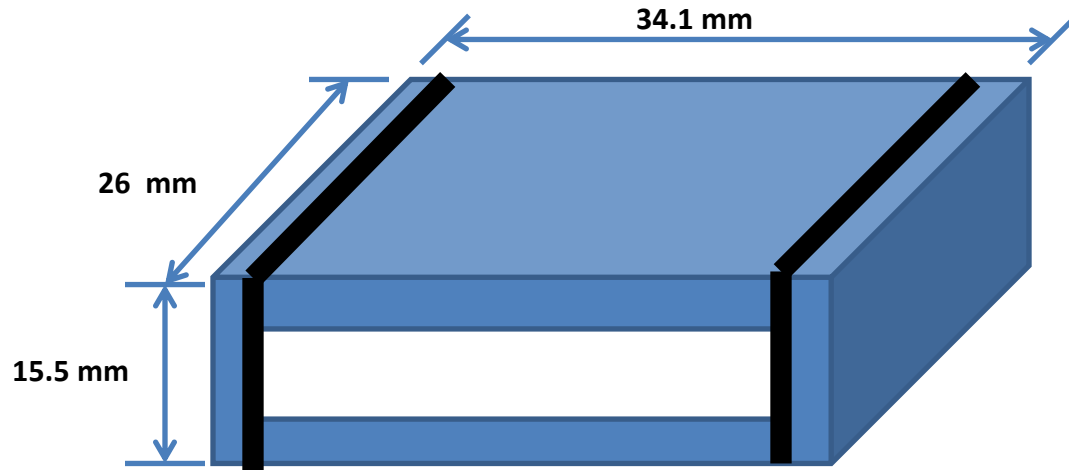

All holes are thru holes

Side parts (material: brass)

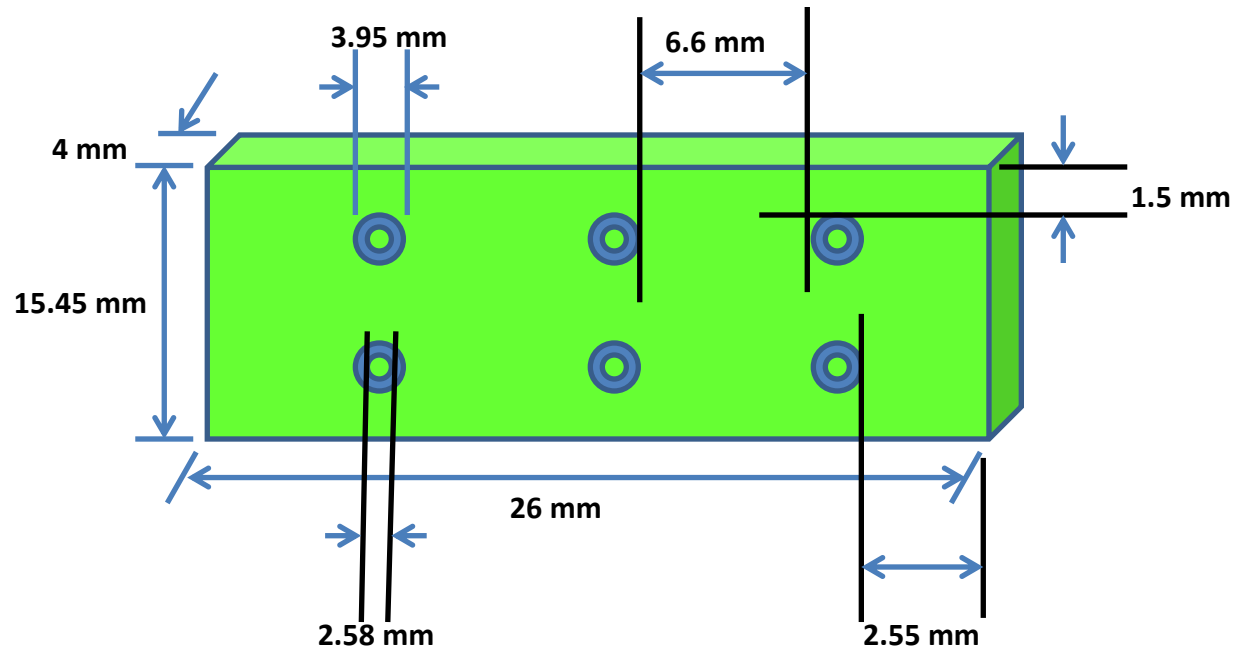

Top part (Material: steel)

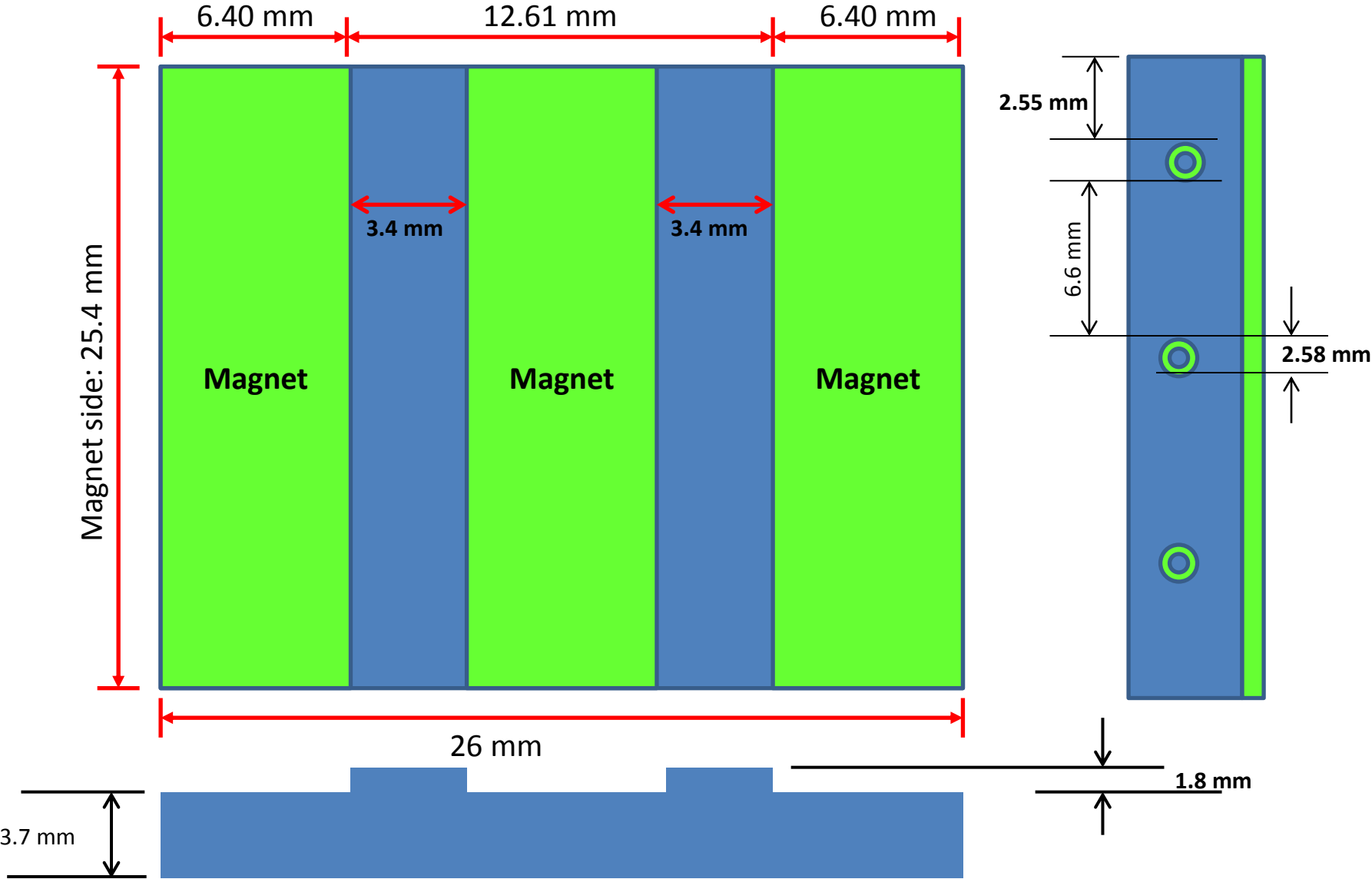

Bottom part (Material: steel)

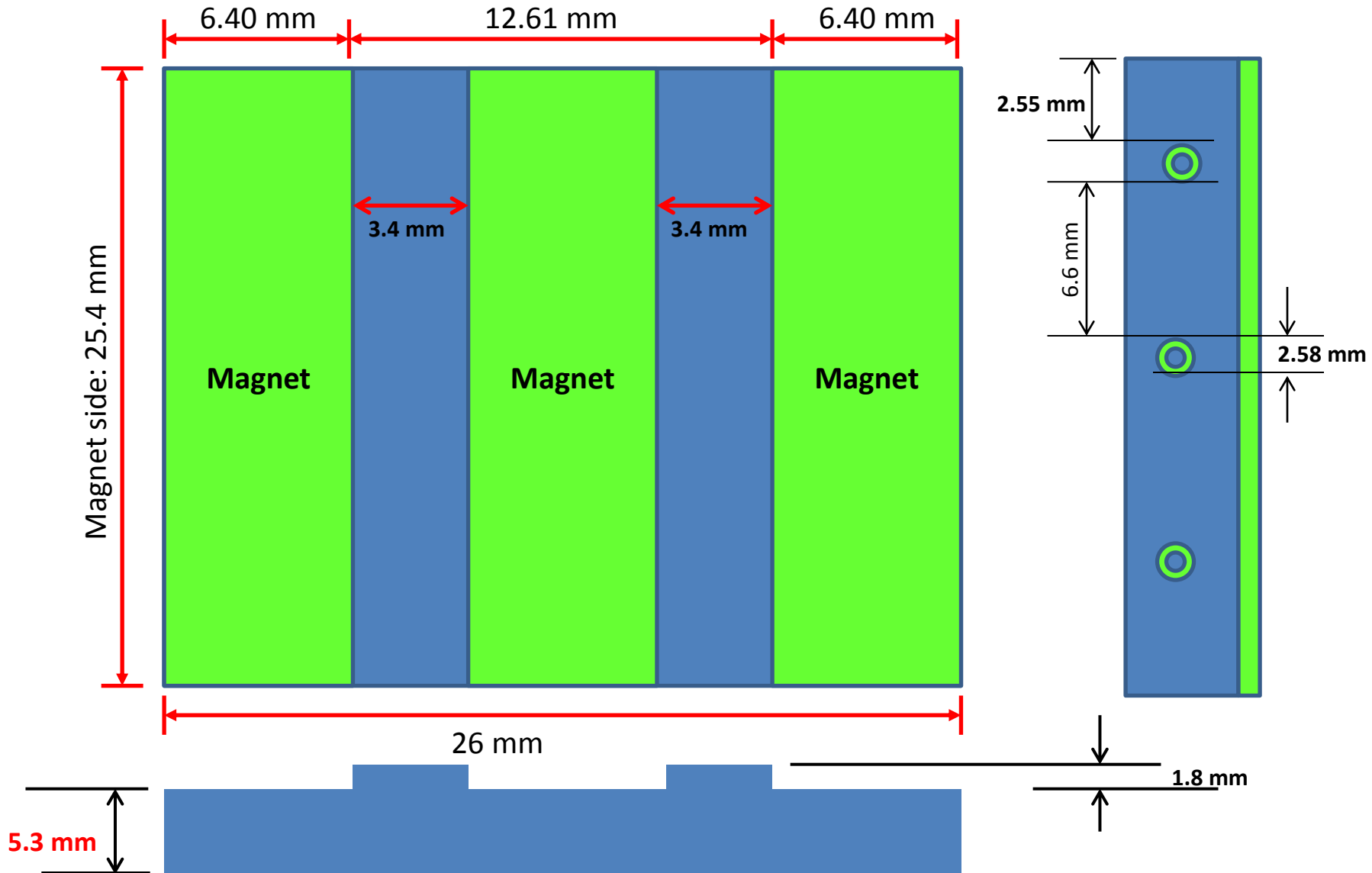

Bottom part (other side) (cont.) (Material: steel)

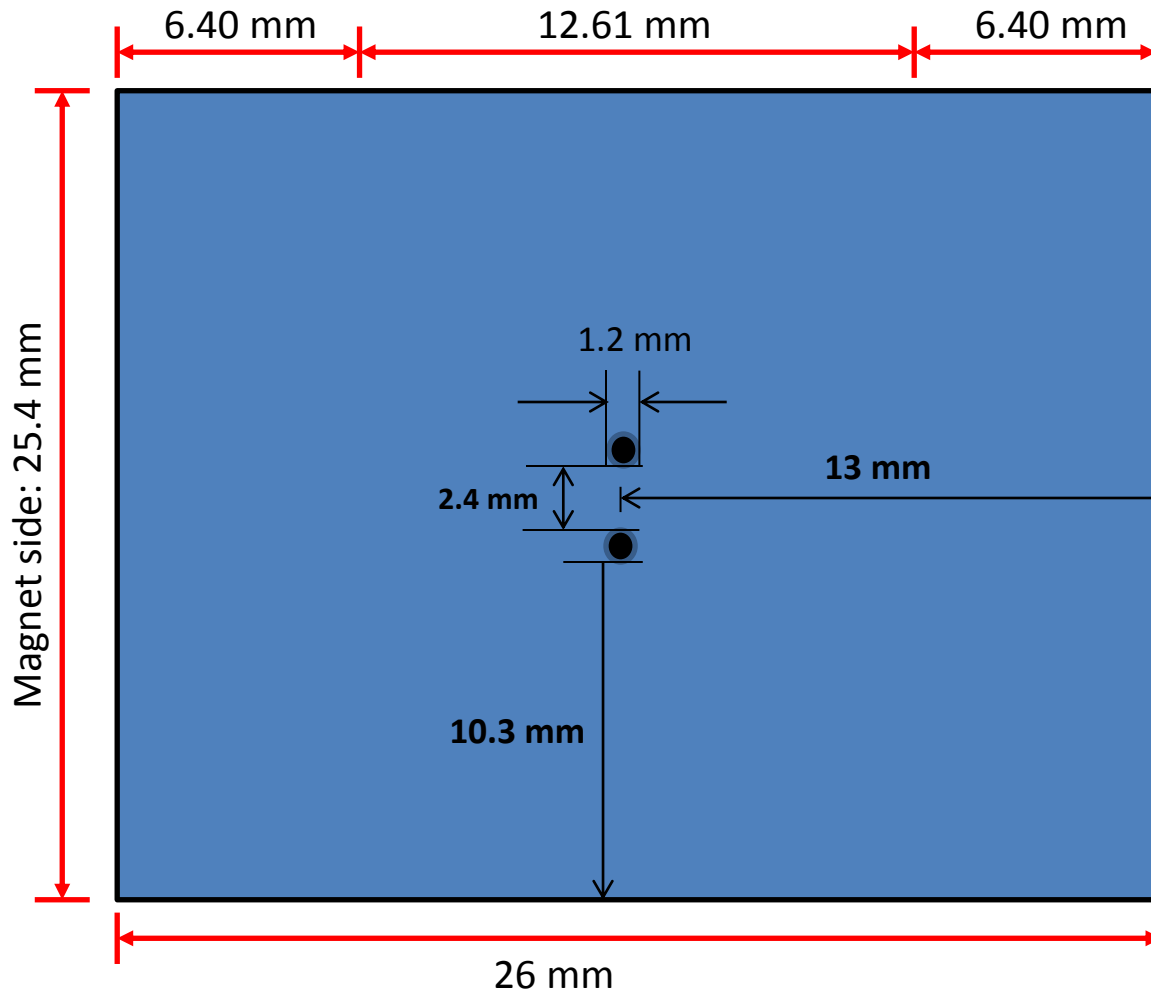

Base (approximated)
(Material: Aluminum)

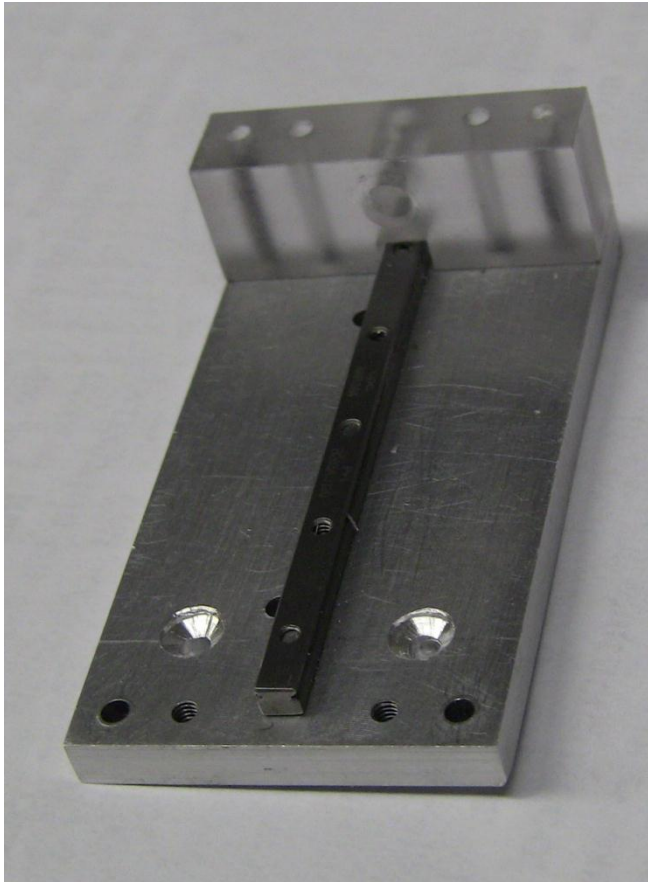

Base thickness: 4 mm
Material: Aluminum.

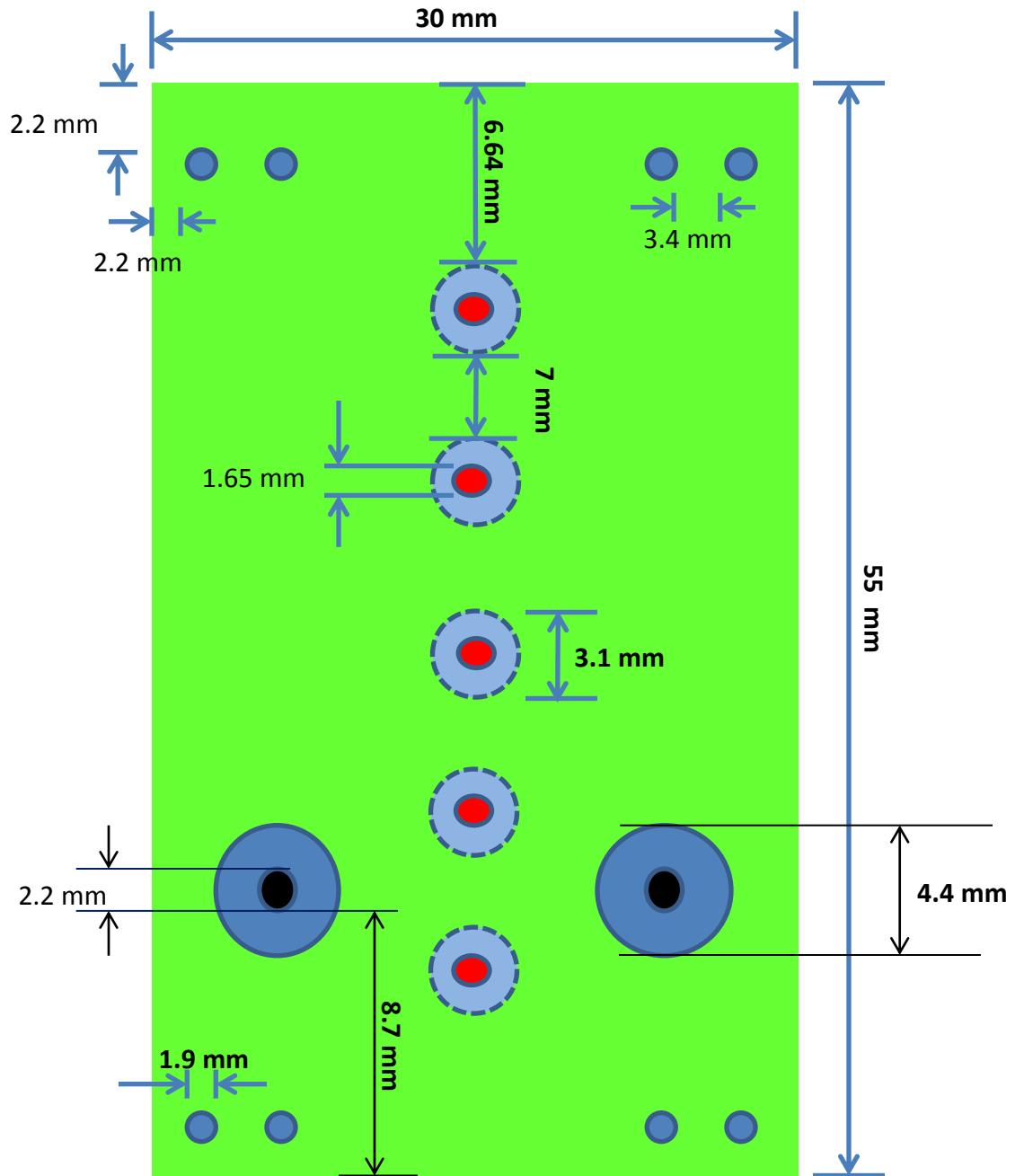

Wall (Material: Lexan)

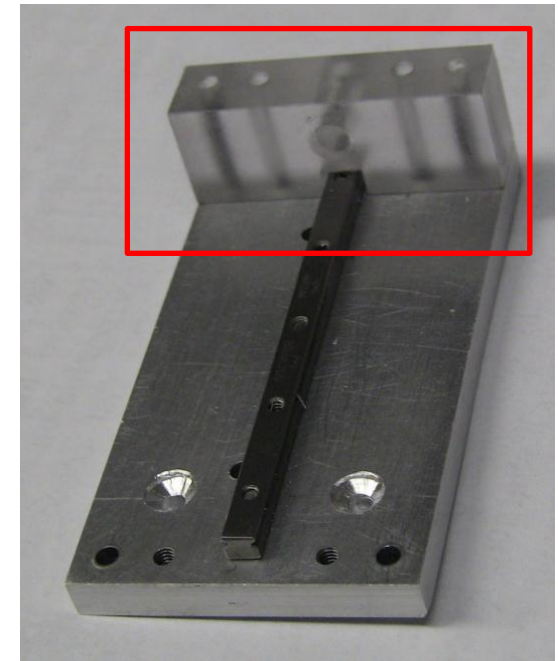
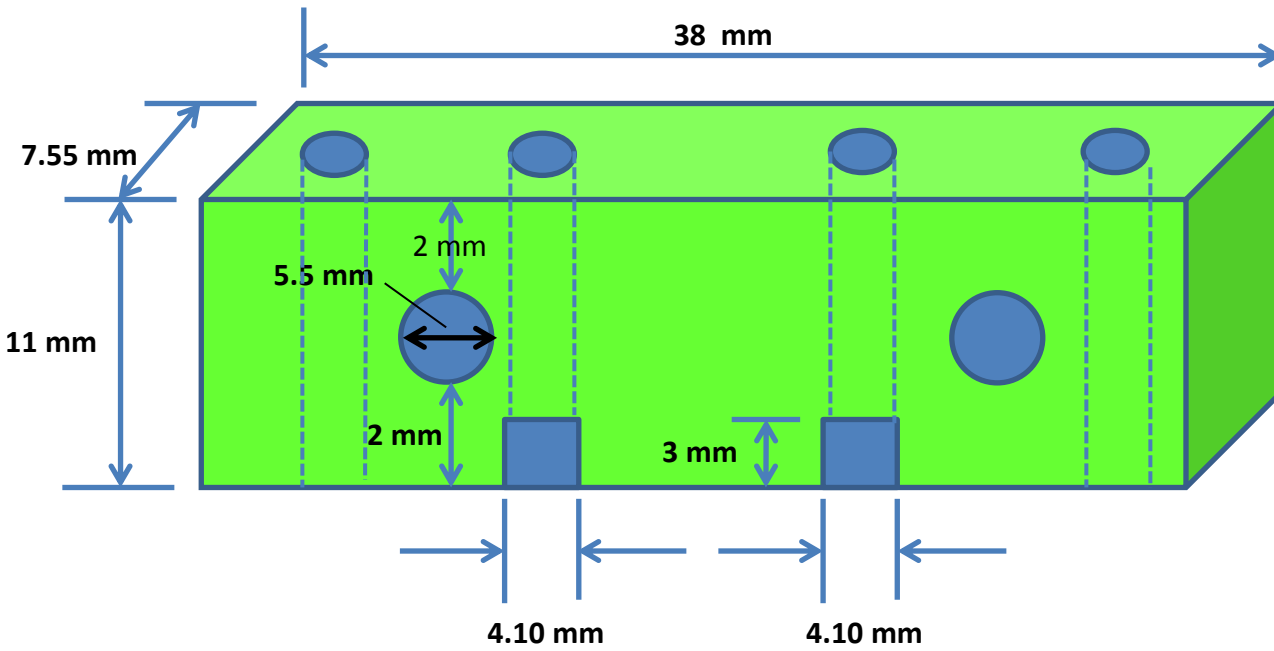

Top view

